

# Class 250 • Bolted Bonnet • OS&Y • Bronze Trim • Flanged

## F-667 Gate Valve

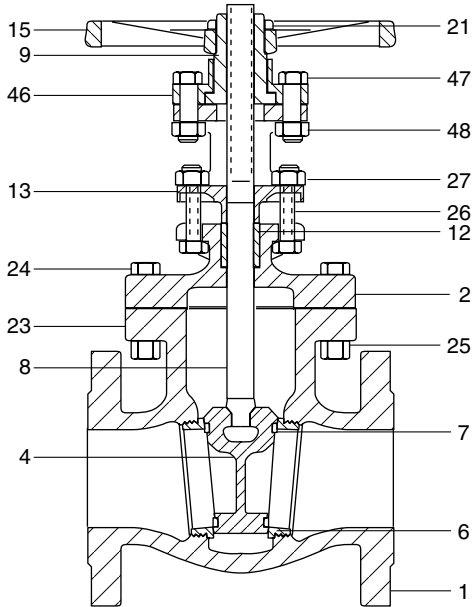

<b>Industry Standards</b>
MSS SP-70, Type 1

## Materials of Construction

No.	Description	Material	ASTM
1	Body	Cast Iron	A126 Class B
2	Bonnet	Cast Iron	A126 Class B
4	Disc	Bronze (2" - 3")	B584 C84400
		Cast Iron (4" - 12")	A126 Class B
6	Seat Ring	Bronze	B584 C84400
7	Disc Ring	Bronze (4" - 12")	B584 C84400
8	Stem	Manganese Bronze (2" - 4", 6" - 8")	B584 C86400
		Naval Brass (5", 10", 12")	B21 C48500
9	Yoke Sleeve	Manganese Bronze	B584 C86400
12	Packing	Braided Flexible Graphite with Corrosion Inhibitor	
13	Gland	Ductile Iron (2" - 4", 6")	A536 Gr. 65-45-12
		Bronze (8" - 12")	B584 C84400
14	Gland Flange*	Carbon Steel (5")	A307 Gr. B
		Ductile Iron (8" - 12")	A536 Gr. 65-45-12
15	Handwheel	Ductile Iron	A536 Gr. 65-45-12
21	Handwheel Nut	Sintered Nickel Steel (2" - 6")	B484 Gr. 2 Class B Type II
		Ductile Iron (8" - 12")	A536 Gr. 65-45-12
23	Bonnet Gasket	Aramid Fibers with SBR Binder	
24	Bonnet Bolt	Carbon Steel	A307 Gr. B
25	Bonnet Bolt Nut	Carbon Steel	A563 Gr. A
26	Gland Bolt	Carbon Steel (2" - 4", 6" - 8")	A307 Gr. B
		Gland Stud	Carbon Steel (5", 10", 12")
27	Gland Bolt Nut	Carbon Steel Zinc-Plated	A563 Gr. A
46	Yoke Cap	Ductile Iron (2" - 4", 6")	A536 Gr. 65-45-12
		Cast Iron (8")	A126 Class B
47	Yoke Cap Bolt	Carbon Steel	A307 Gr. B
48	Yoke Cap Bolt Nut	Carbon Steel	A563 Gr. A
51	Yoke Hub Bolt*	Carbon Steel (5", 10", 12")	
52	Yoke Hub Bolt Nut*	Carbon Steel (5", 10", 12")	
53	Yoke Pad Bolt*	Carbon Steel (5", 10", 12")	

\* Not shown

See page 5 for Pressure Temperature Ratings

## Dimensions and Weights

Inches (millimeters) - Pounds (kilograms)

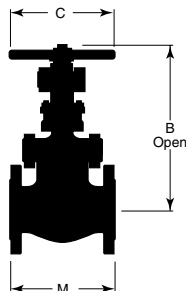

Valve Size	Dimensions			WT
	B	C	M	
2	15.06	8.00	8.50	54
	(382)	(203)	(216)	(24)
2 1/2	16.69	8.00	9.50	80
	(424)	(203)	(241)	(36)
3	18.75	10.00	11.12	114
	(476)	(254)	(282)	(52)
4	23.44	12.00	12.00	174
	(595)	(305)	(305)	(79)
5	24.00	14.00	15.00	280
	609	356	381	127
6	31.75	16.00	15.88	332
	(806)	(406)	(403)	(151)
8	39.88	18.00	16.50	600
	(1,012)	(457)	(419)	(270)
10	41.75	22.00	18.00	920
	(1060)	(559)	(457)	(417)
12	47.00	24.00	19.75	1400
	(1193)	(610)	(502)	(635)